

- Installation instruction
- Lighting Instructions

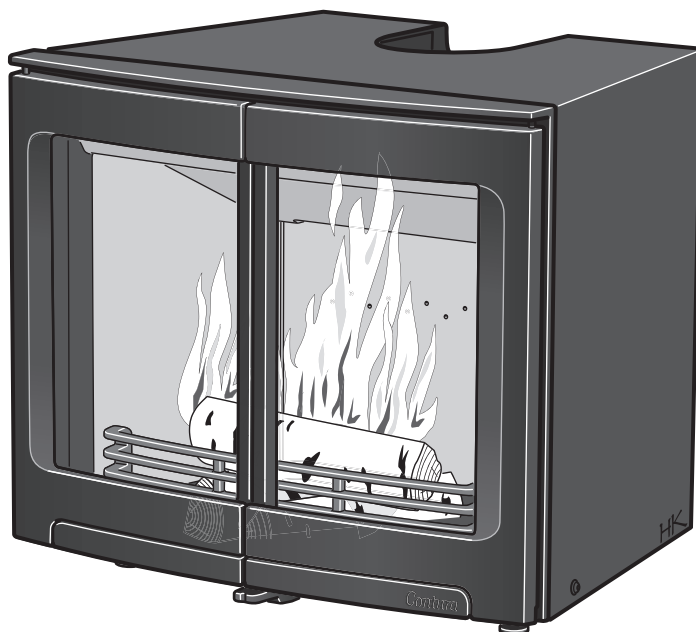
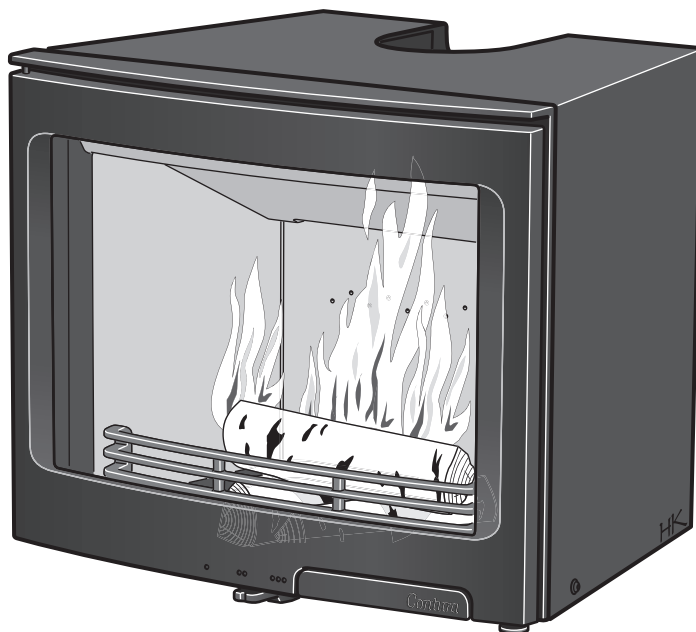

C i5

Contura

DECLARATION OF PERFORMANCE

No. Ci5-CPR-130622-SE-1

Contura

PRODUCT

Product type Insert lit with solid biofuels
 Type designation Contura i5
 Manufacturing number See rating plate on the insert
 Intended area of use Heating of rooms in residential buildings
 Fuel Wood

MANUFACTURER

Name NIBE AB / Contura
 Address Box 134, Skulptörvägen 10
 SE-285 23 Markaryd, Sweden

CHECKS

According to AVCP System 3
 European standard EN 13229:2001 / A2:2004
 Test institute Rein-Ruhr Feuerstätten Prüfstelle, NB 1625,
 has checked declared performance and issued test report no. RRF-29 12 3029

DECLARED PERFORMANCE

Essential characteristics	Performance	Harmonised technical specification
Reaction to fire	A1 WT	EN 13229:2001 / A2:2004
Minimum distance to combustible material	Intended for installation in an existing open hearth.	
Risk of falling embers	Approved	
Emissions from combustion Wood	CO 0.10% NOx 121 mg/m ³ OGC 109 mg/m ³ PM 19 mg/m ³	
Surface temperatures	Approved	
Cleaning options	Approved	
Mechanical durability	Approved	
Emissions of hazardous substances	Approved	
Nominal output	5 kW	
Efficiency	78%	
Flue gas temperature in connector at nominal output	270°C	

The undersigned is responsible for the manufacture and conformity with the declared performance.



Niklas Gunnarsson, Business area manager NIBE STOVES
 Markaryd, 1st July 2013



A warm welcome to Contura.

A warm welcome to the Contura family. We hope you will get a great deal of pleasure from your new cassette. As a new owner of a Contura cassette, you have secured a product with timeless design and long service life. Contura also has a combustion process that is both environmentally friendly and efficient, for the best heat production.

Read through these installation instructions carefully before installation. Read how to best light your stove in the section with lighting instructions.

List of Contents

<u>Installation instruction</u>	
Technical details / Dimensions	100
Supply of combustion air	101
Requirements for chimney	101
Installation	102
<u>Lighting instructions</u>	
Lighting in the right way	108
Maintenance	109
Possible causes for interruption in operation	110

NOTE:

Report the installation of a cassette to your local building authority.

The owner of the house is personally responsible for ensuring compliance with the mandatory safety requirements and must have the installation approved by a qualified inspector. Your local chimney sweep must also be informed about the installation as this will affect the routines for regular chimney-sweeping services.

WARNING!

The cassette becomes very hot

During operation, certain surfaces of the cassette become very hot and can cause burn injury if touched. Also, take heed of the strong heat radiated through the door glass. Placing flammable material closer than the safe distance indicated may cause a fire. Smoulder combustion can cause quick gas ignition with the risk of damage to property and personal injury.

Technical details

Output	3-9 kW
Nominal output	5 kW
Efficiency	78 %
Weight (kg)	77.5
Width (mm)	550
Depth (mm)	433
Height (mm)	480 ± 10

Type approved in accordance with:
European standard EN-13229 (DE/A), DINplus,
Part 15a B-VG in accordance with test report
RRF- 29 12 3029
Norwegian standard, SINTEF - 110-0391
Type approved in SE in accordance with
SITAC xxx

Installation by authorised technician

This manual contains instructions about how the cassette must be assembled and installed. To ensure the function and safety of the cassette, we recommend that the installation is carried out by an authorised technician. Contact one of our dealers who can recommend suitable fitters.

Dimensions

C 15

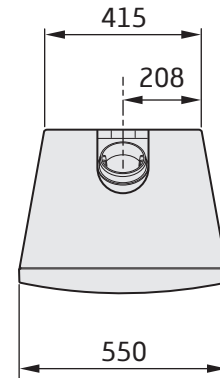
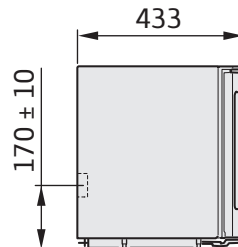
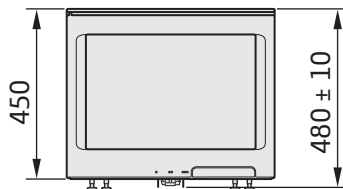

Alternative flue connections

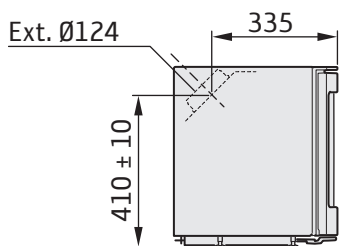

Flue connection - 45° Rear

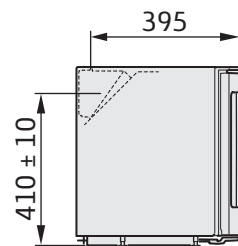

Flue connection - Rear

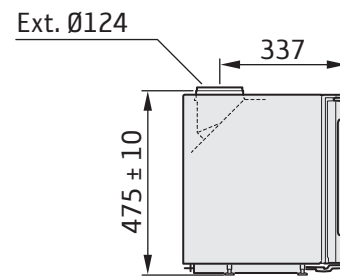

Flue connection - Top

Supply of combustion air

For optimum function and efficiency a supply air connection (accessory) is recommended via a separate channel. The air can be supplied indirectly via a vent in the outer wall, or directly through a duct from outside.

The connector on the supply air connector has an outer diameter

of $\varnothing 67$ mm. When duct routing further than 1 m the pipe diameter must be increased to 100 mm and a correspondingly larger wall vent must be selected. The amount of air needed for combustion is approx. 20 m³/h.

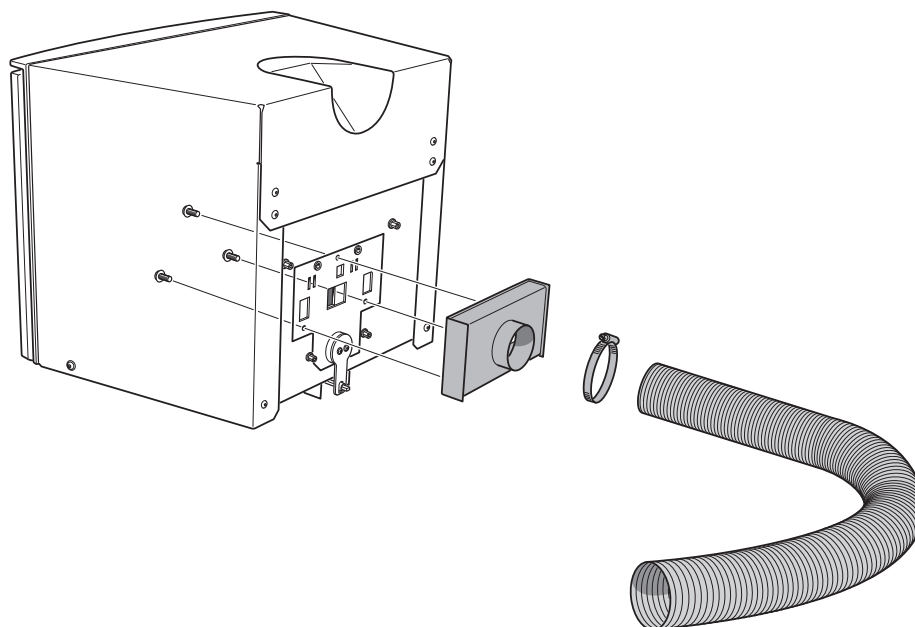

Requirements for the chimney

- The cassette meets the requirements for connecting to chimneys dimensioned for 350 °C flue gas temperatures.
- The connection sleeve's outer diameter is 125 mm.
- The cassette requires a draft in the chimney of at least -12 Pa. The draft is affected both by the length and area of the chimney, and by how well sealed it is. The minimum recommended chimney length is 3.5 m and suitable cross-sectional area is 120-175 cm² (125-150 mm in diameter).
- A flue with sharp bends and horizontal routing reduces the draught in the chimney. The maximum horizontal flue is 1 m, on the condition that the vertical flue length is at least 5 m.
- It must be possible to sweep the full length of the flue and the soot doors must be easily accessible.
- Carefully check that the chimney is sealed and that there is no leakage around soot doors and flue connections.

Installation

The cassette is designed to be installed in existing open hearths.

There must be a 20 mm air gap around the cassette for optimum hot air convection.

Use the cardboard template and check that there is sufficient space for the installation. Fold out template to see where the sleeve connection ends up.

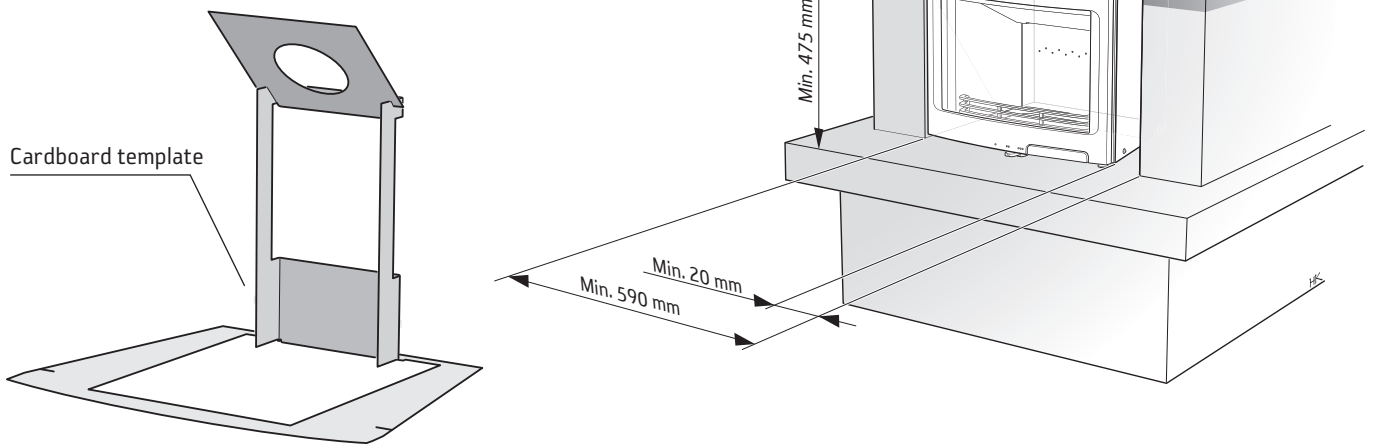

The cassette can be connected to the chimney from above, the back or at angle of 45°, depending on the choice of sleeve.

Due to the risk of falling embers, a flammable floor must be protected by a hearth plate. The hearth plate must extend 300 mm in front of the hearth and can consist of natural stone, concrete, metal or glass. The minimum distance in front of the hearth to combustible parts of the building or interior decoration must be at least 1 metre.

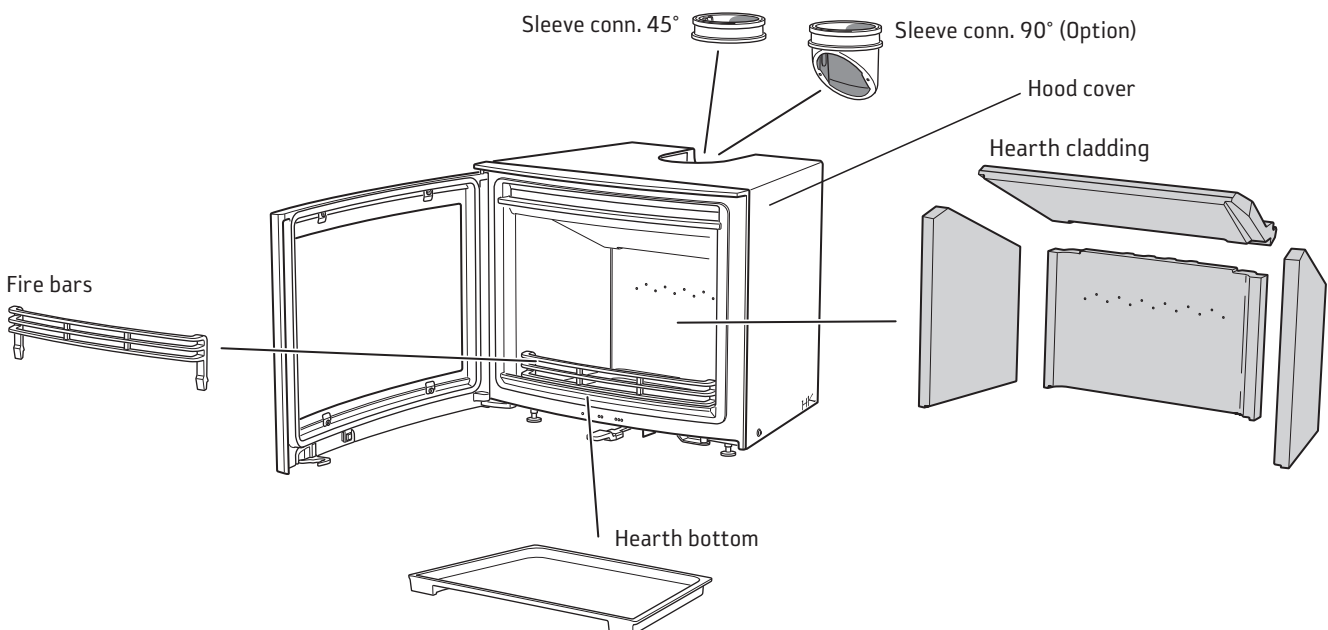

Preparations

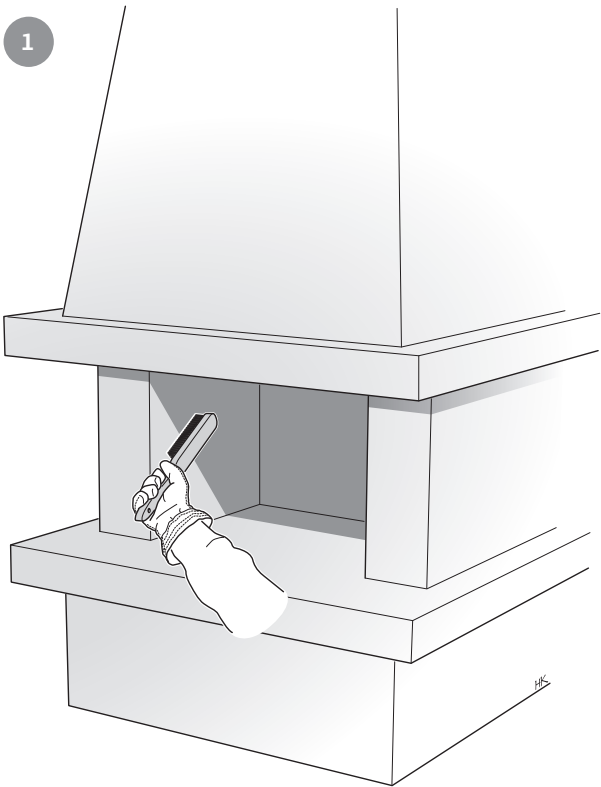

Remove any old damper sheets and clean the stove.

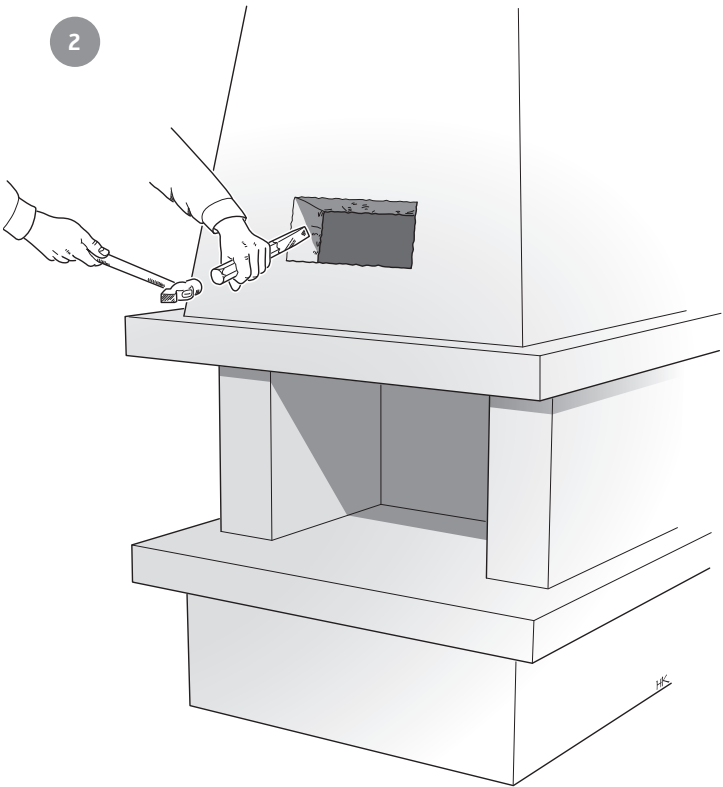

To simplify installation a hole can be made in the stove hood. After installation is completed this can be fitted with a grille and provide additional heating.

Removing the internal parts

Remove internal loose cast iron components and fire bricks as follows.



Handle the hearth cladding with care.

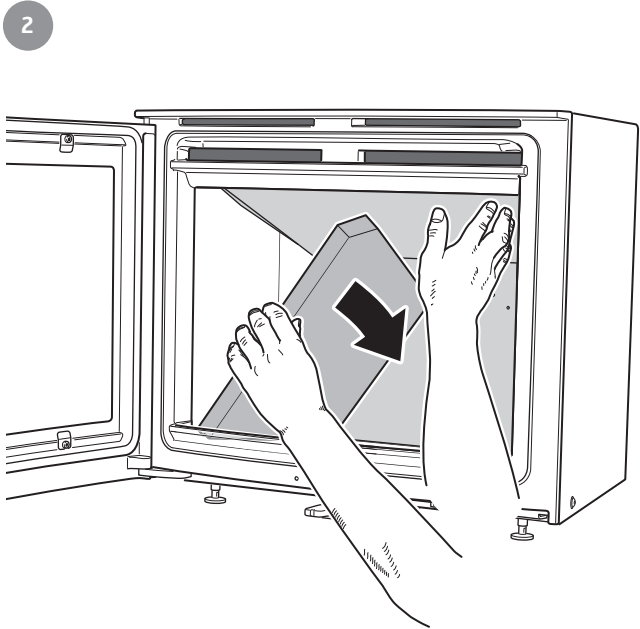
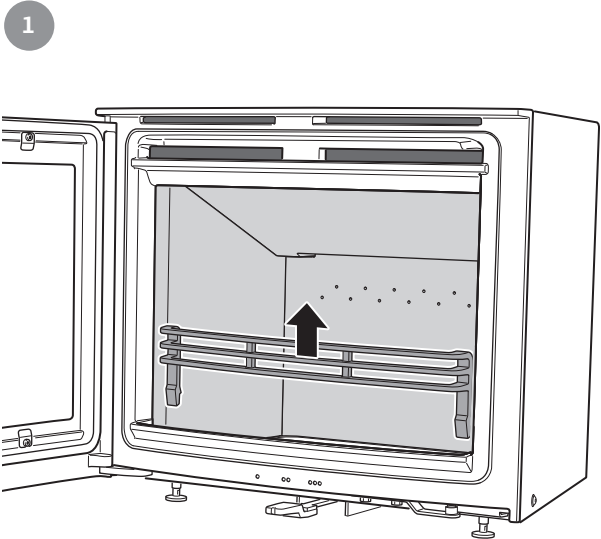

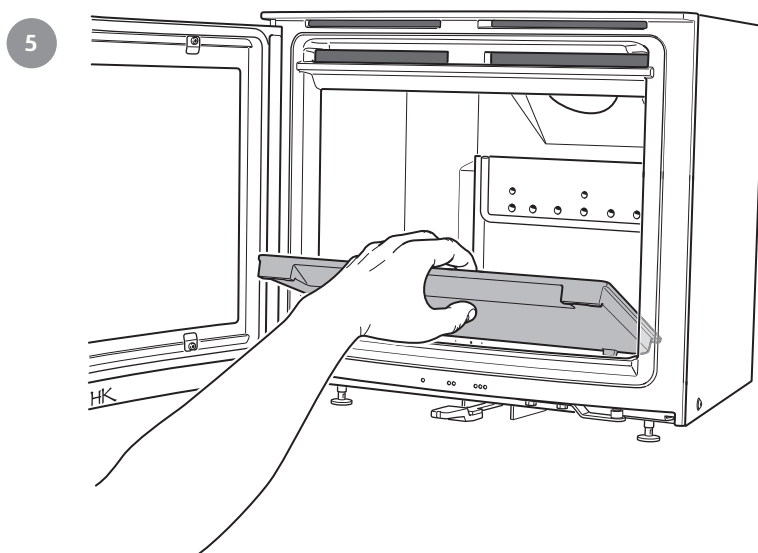
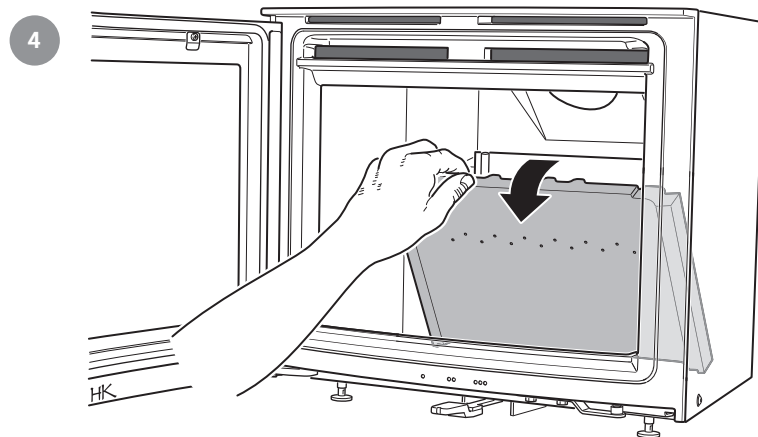
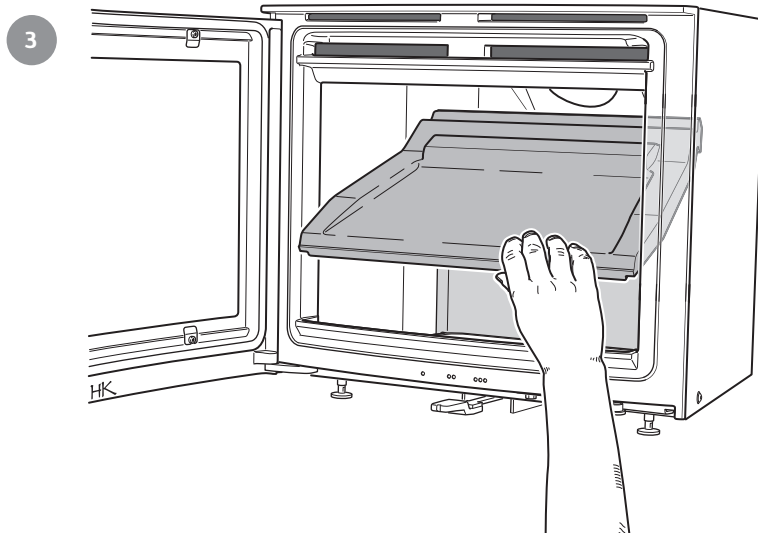

Connection to chimney

A flexible hose is recommended for ease of installation (sold as an accessory). Secure the sleeve in the hose. Connect and seal carefully between the hose and the chimney according to the separate instruction. Angle the hose so that the sleeve connector ends up where the template shows the cassette's connection surface

 Seal carefully between the hose and the chimney using mineral wool.

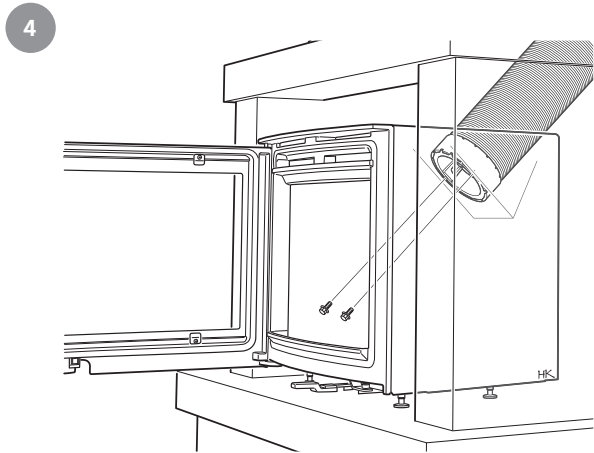
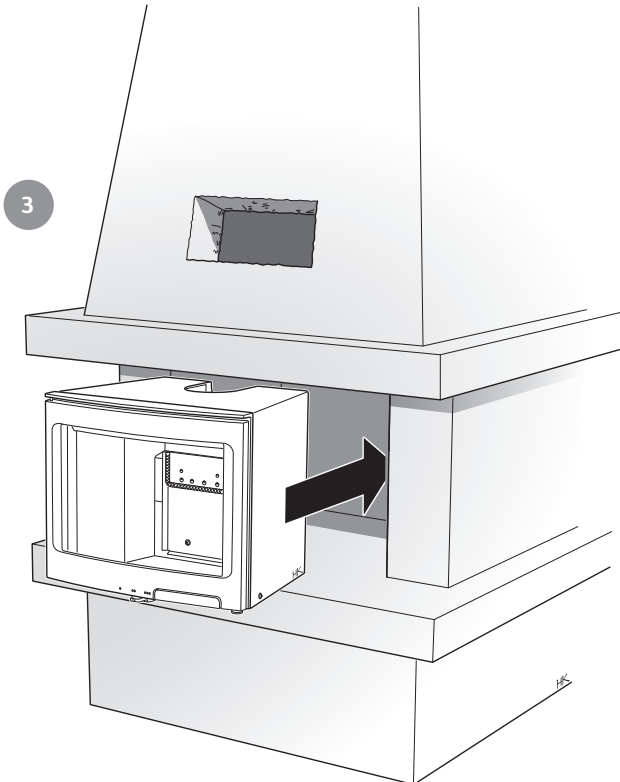
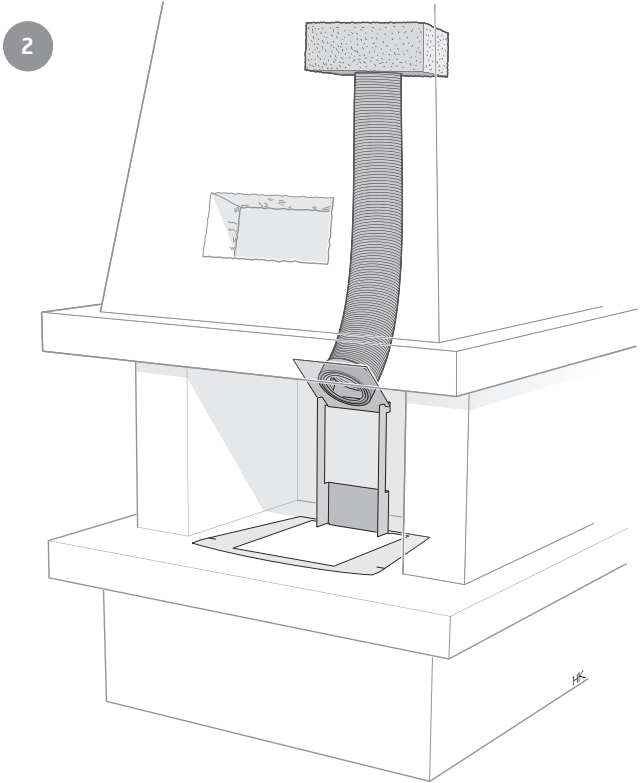
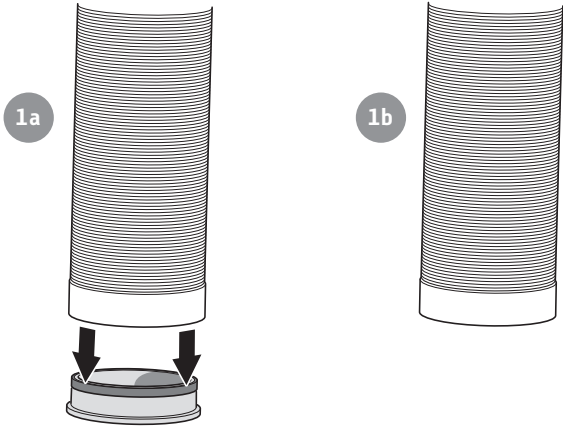

Alternative connection to chimney

The cassette can also be connected with fixed pipe inserted up the chimney



Seal carefully between the hose and the chimney using mineral wool and seal any pipe joints using heat-resistant sealant.

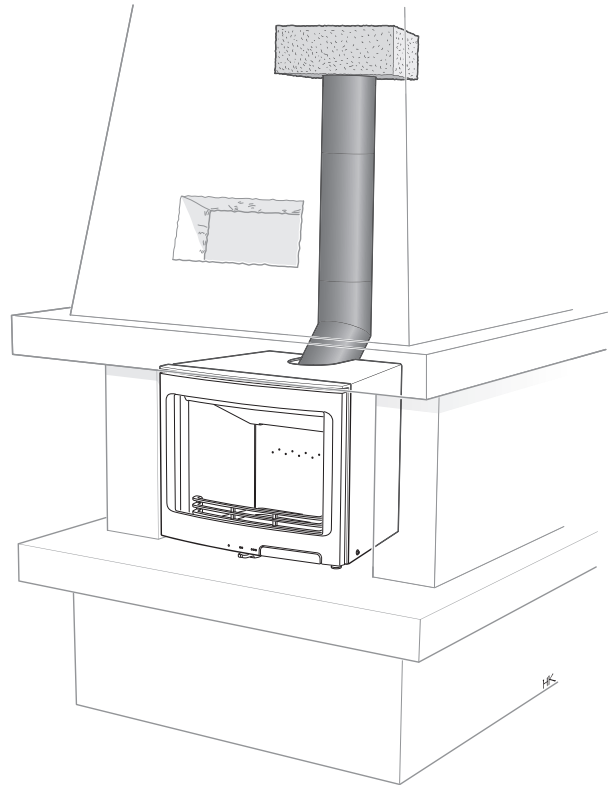

Connection

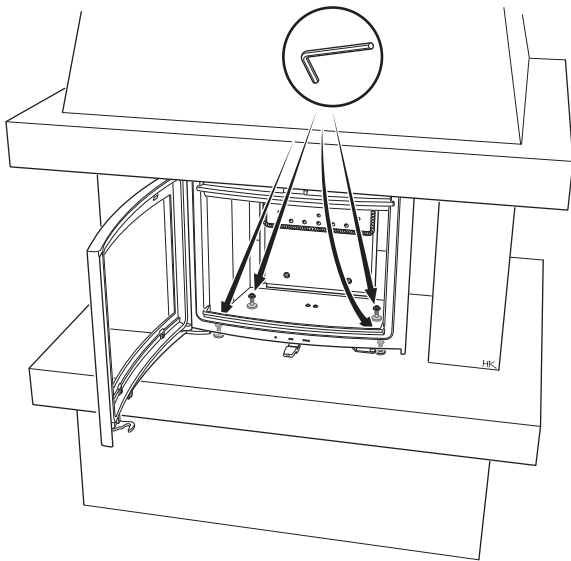

Ensure that the cassette is stable by adjusting the feet.

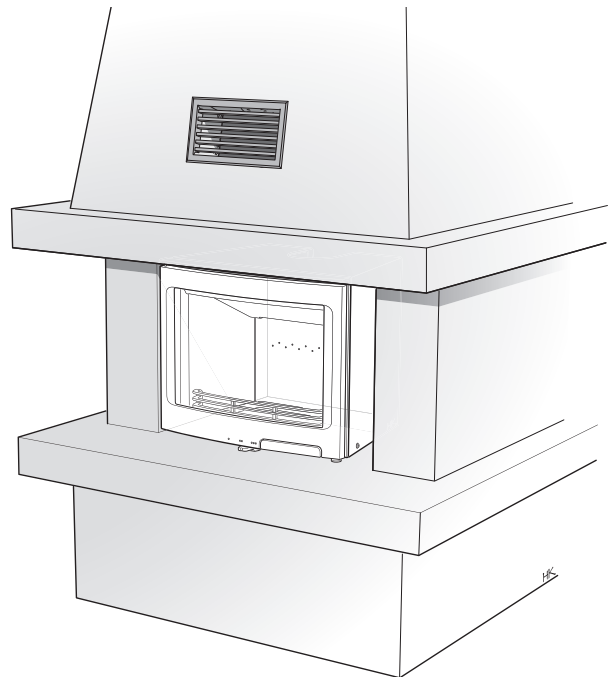

Reinstall the internal components in reverse order.

Final inspection of the installation

It is extremely important that the installation is inspected by an authorised chimney sweep before the cassette is used. Also read the "Lighting instructions" before lighting for the first time.



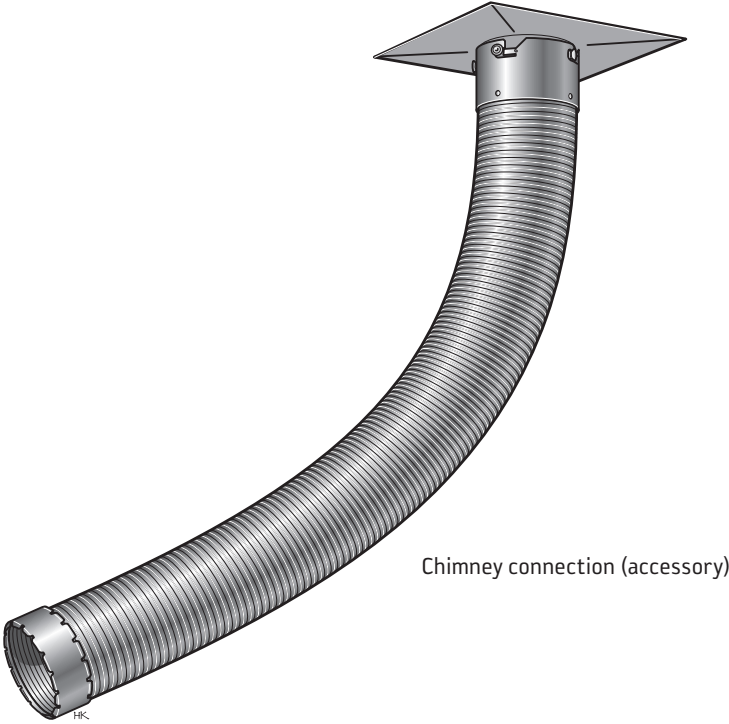
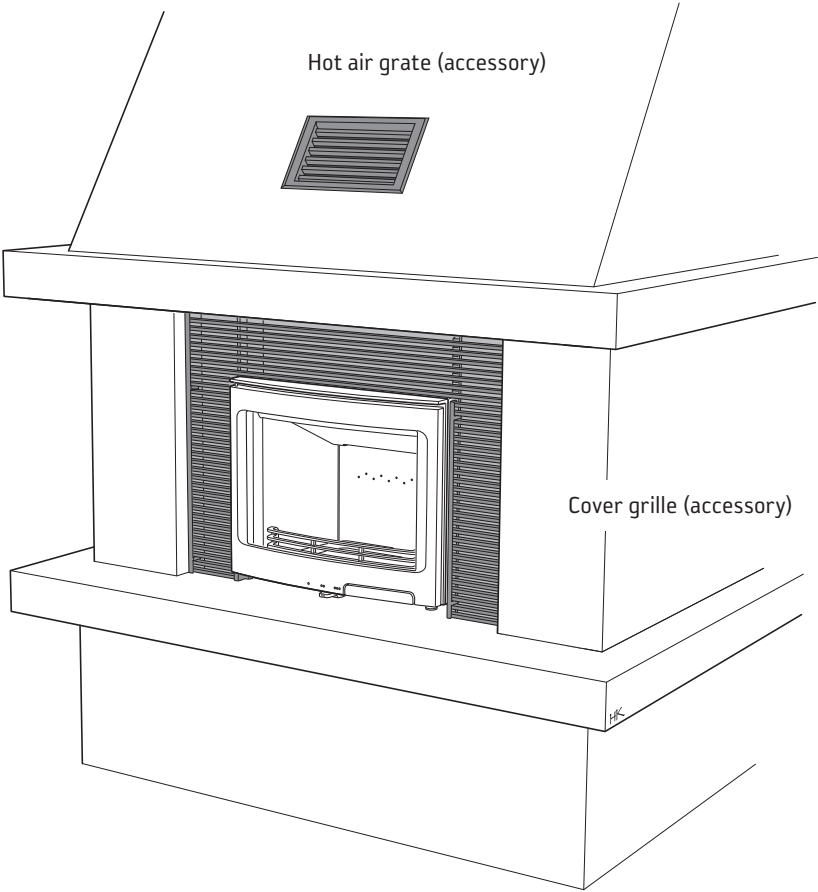

Lighting instructions

Lighting in the right way

Contura i5 is intended to produce secondary heating for the accommodation. It is important that the correct amount of wood is used, especially when lighting. If you are lighting the fire for the first time you should use a set of scales to see how much 1.5 kg kindling is. Also check what the normal and maximum weights look like.

The cassette may only be lit with the hatch closed. Always open the hatch carefully and slowly to prevent blow back because of the changing pressure in the stove.

The function of the cassette differs depending on the draft conditions in the chimney. Achieving the correct setting for the combustion air damper usually takes a few attempts.

Correctly sized wood

Note that if too little kindling is used when lighting, or if the wood is too thickly cut, the fire box will not reach the correct operating temperature. Incorrect lighting can lead to poor combustion with heavy sooting and may result in the fire going out when the hatch is shut.

Lighting logs: Finely chopped wood

Length: 25-33 cm

Diameter: 3-4 cm

Weight per lighting: 1.5 kg (approx. 12-15 finely chopped pieces)

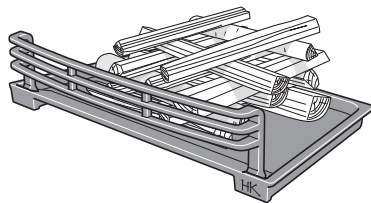

Feeding Wood: Split logs

Length: 25-33 cm

Diameter: 6-7 cm

Normal weight: 1.5 kg/hour (1-2 pieces per insertion)

Max amount: 3 kg/hour (1-2 pieces per insertion)

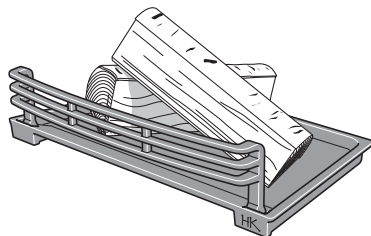

Lighting

If the house has mechanical ventilation, open a window near to the fireplace prior to lighting. Leave the window open for a few minutes until the fire has caught properly.

1. Open the combustion air damper completely.
2. Insert paper or firelighters and about 1.5 kg of thinly chopped kindling into the firebox. Stack the wood crosswise.
3. Light the fire.
4. Set the hatch to the lighting position, that is the lock catch's first lock position against the lock roller to create a sufficient air gap between the hatch and the cassette.
5. When the fire has caught fully after approx 10-15 minutes, close the hatch completely.
6. A fresh load of logs should not be put on until the start-up fire has become a glowing bed of embers.

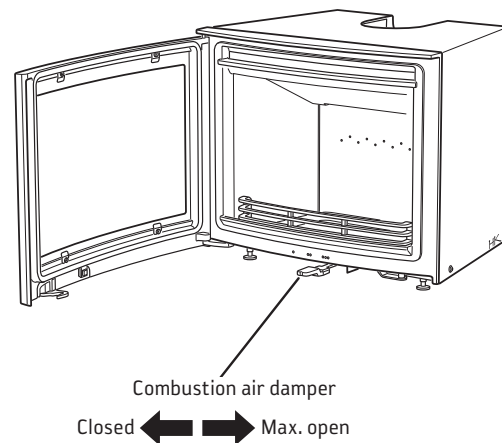

Adding wood

1. Open the hatch a few centimetres and allow the vacuum in the firebox to equalise for a few seconds before opening the hatch fully.
2. Add two logs with a combined weight of approx 1-1.5 kg. Place one log diagonally and one parallel to the back plate. Then close the hatch. The combustion damper must be completely open for 5 minutes until the logs turn black and are burning thoroughly.
3. If slower combustion is then required, the supply of combustion air can be reduced. The nominal output of 5 kW is obtained when the combustion air damper is 50 % open and two logs are lit. In this operating position it is important that the air intake damper is fully open for the first 5 minutes so that the wood has time to burn properly before the supply of combustion air is reduced. A condition for regulating the output is a thick bed of embers and high temperature in the firebox. When the fire has died down to embers more wood should be added. The conditions for controlling combustion vary depending on the temperature in the combustion chamber and the draft in the chimney.

Important!

It is important that the wood catches fire quickly. Quick lighting is achieved by opening the combustion air damper fully or by leaving the hatch ajar for a moment. Pyre lighting gives poor combustion and produces a lot of smoke and can cause quick gas ignition in the worst instance resulting in hearth damage.



Maintenance

Not too big fires

Fires should not be too big. Large fires are uneconomical and they give off high flue gas temperatures that can damage the cassette and the environment. Recommended amount of wood for normal use is 1.5 kg/hour, with the maximum permitted amount of 3 kg/hour when lighting with chopped birch wood or other broad leaf wood with a moisture content of about 18 %. When lighting with the same wood amounts as above but with, for example, conifer wood, higher fireplace temperatures are achieved. The service life of the fireplace can be cut short if the fire is left at full combustion for long periods, and if the maximum permitted amount of wood is exceeded, parts in the stove can become damaged thus voiding the warranty.

Choosing fuel

All types of wood, such as birch, beech, oak, elm, ash, conifers and fruit trees can be used as fuel in the cassette. Different types of trees have different densities, the greater the density of the wood the greater the energy value. Oak, beech and birch have the highest density.



The wood's moisture content

Fresh wood is about 50 per cent water. Some of the water circulates freely between the fibres and some of the water is bound in the cells. The wood must always be dried so that the free water evaporates. The timber is ready for use when the moisture content has fallen below 20 %. If wood with a higher moisture content is lit, a large part of the energy content of the wood is used boiling off the water. If the wood is damp, the combustion is also poor, layers of soot and tar build up in the chimney and could, at worst, lead to a chimney fire. In addition, it causes the glass of the stove to soot and may cause discomfort to those living nearby.

To ensure thoroughly dry wood, the wood should be cut in the winter and stored, well aired, under a roof. Never cover the woodpile with a tarpaulin to the ground. The tarpaulin will then act as a sealed cover and the wood will be prevented from drying. Always store a small amount of wood indoors for several days before use, so that the surface moisture has time to evaporate.

Do NOT burn the following

Under no circumstances may pressure impregnated wood, painted or glued wood, chipboard, plastic or colour brochures be used as fuel. All these materials can create hydrochloric acid and heavy metals that are damaging both to the environment and the hearth. Hydrochloric acid can also attack the steel in the chimney or the mortar in a stone built chimney.

The glass may become sooty with use, even if lit with dry wood with a moisture content of 15 – 20%. Regular cleaning with dry paper is usually sufficient to keep it clean. If the soot has been on the glass for a prolonged period use a cleaning agent or a special soot removal agent to remove it. Such agents can be purchased from regular hardware stores or from your local stove dealer.

Never use cleaning agents that contain any abrasives, these can damage the glass.

When emptying the ash, ensure that there are no glowing embers. The ash must be stored in a fireproof container with a lid for at least one week before being disposed of.

Cast iron parts are cleaned using a steel brush.

It is important from a combustion point of view to check gaskets, as worn gaskets hinder combustion when the stove draws "extra air".

Painted parts on the cassette can be cleaned using a damp cloth, with a small amount of detergent, if necessary. Damage to painted parts, e.g. small scratches, can be rectified with Contura touch-up paint. Contact the dealer.

Parts located near the actual seat of the fire may require replacing. Examples of such parts are the hearth surround. The service life of these parts depends on how much and how the cassette is used.

When the cassette is new

When new, the cassette may emit an odour due to excess paint and oil coating that may remain on the panels. The odour will disappear completely after several fires.

Managing waste

The cassette packaging is cardboard, wood and a small amount of plastic. The materials must be sorted and recycled.

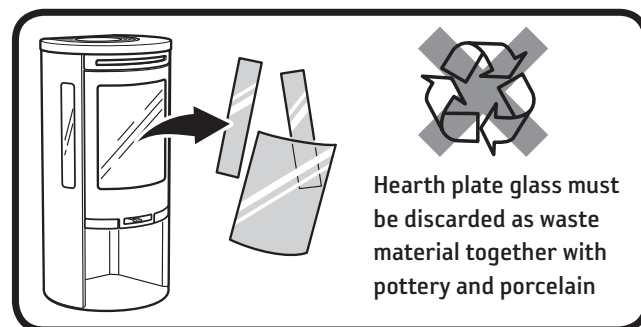

Possible causes of malfunctions and how to rectify them

Poor draft in the cassette after new installation

- Check that the chimney length meets Contura's recommendation, which is at least 3,5 m.
- Check that there is nothing in the chimney to restrict the smoke and that no nearby buildings or trees affect the winds around the chimney.
- Check the chimney area (applies to existing chimneys). The area must be 120–175 cm².

It is difficult to light the fire and the fire dies after a short time

- The wood may not be dry enough, check the wood.
- Another reason is that there may be negative pressure in the house, for example when using a kitchen extractor fan or other mechanical ventilation. Open a window near the cassette before lighting the fire. Also try lighting some newspaper and holding it up inside the firebox to get the draft going.
- The supply air duct from outdoors can be partially or totally blocked. Remove the hose and try test lighting with combustion air from the room.

Check that the combustion air damper is in the correct position, see the instructions

- The smoke outlet of the cassette may be blocked with soot, which can occur after sweeping. Lift the smoke baffle out and check.
- Finally, go through the lighting instructions again. Perhaps the amount of kindling was too small and therefore the base embers were too weak and cold to light the next load of wood.

Abnormal amounts of soot form on the glass

There is always a certain amount of soot on the glass and this is added to with each lighting. Soot on the glass is caused by three things:

- The wood is damp, which causes poor combustion and generates a lot of smoke as a result.
- Too low temperature in the firebox, which causes incomplete combustion and poor draft in the chimney.
- Handling is not correct, for example the hatch was not in the lighting position for 15 min.

Check the moisture content of the wood, ensure that you have good base embers and go through the lighting instructions one more time.

Smoke odour around the cassette for periods

This can occur when wind blows down the chimney and most often occurs when the wind is from a particular direction. Another reason could be that the hatch was opened when there was a lot of flame.

Painted parts have become discoloured

If painted parts have discoloured it is due to excessive temperature in the firebox. The reason for the excessive temperature can be that the maximum amount of wood has been exceeded, inappropriate fuel has been used (for example building waste, large quantities of finely chopped off cuts). The warranty does not cover damage of this type.

If a problem occurs that you cannot rectify yourself, contact the dealer or a chimney sweep.

We hope that these lighting tips give you enjoyable, economical and problem free use of your Contura cassette.

SWEEPING

Sweeping the chimney ducts and chimney connections should be carried out by a chimney sweep. Sweep the cassette by scraping and/or brushing. A soot vacuum cleaner is most appropriate however. If a chimney fire occurs or is suspected, the combustion damper and the door must be closed. If necessary, contact the fire brigade to extinguish it. The chimney must always be inspected by a chimney sweep after a chimney fire.



- During operation, certain surfaces of the cassette become very hot and can cause burn injury if touched.
- Also, take heed of the strong heat radiated through the door glass.
- Placing flammable material closer than the safe distance indicated may cause a fire.
- Smoulder combustion can cause quick gas ignition with the risk of damage to property and personal injury.

Contura

NIBE AB · Box 134 · SE-285 23 Markaryd · Sweden
www.contura.eu

Contura reserves the right to change colours, materials,
dimensions and models at any time without special notice.
Your dealer can give you the most up to date information.
Stoves shown in brochures may have extra equipment.

811175 IAV SE-EX Ci5-6
2013-12-18